



MODEL NUMBER

2005-2010 FORD MUSTANG AIRBAG STEERING WHEEL REPLACEMENT PROCEDURES

Congratulations on the purchase of your new **GRANT REVOLUTION** steering wheel. This wheel is a direct replacement for your original factory steering wheel. The original airbag (SIR) module, horn switch, switch harness, switches and rear shroud from the factory wheel must be removed and transferred to the new **GRANT** wheel.

This wheel will fit Mustang vehicles equipped with spoke mounted cruise control switches and silver spoke trim only.

IMPORTANT - PLEASE READ

These **GRANT** Instructions use the factory shop manual procedures for the removal and reinstallation of the steering wheel and airbag module. In addition the **GRANT** instructions include step-by- step procedures for the changeover of the switches, wiring and trim pieces from the factory wheel to the Grant wheel. Before proceeding with the replacement of your original steering wheel, it is necessary to read and understand all these instructions. By reading them first, you can become familiar with the steps and terminology used. Please take note of the following directives used throughout these instructions:

ALWAYS CAUTION NEVER NOTICE NOTE

NOTICE - **GRANT** recommends that installation be performed by a qualified service provider such as your local Ford dealer, a certified mechanic, collision repair shop or a local airbag service center. Many of these service centers will come to your home or place of business to change out the air bag and wheel for a nominal fee. To find these providers check the internet for “airbag service”, “mobile airbag service” or check the yellow pages.

CAUTION

ALWAYS WEAR SAFETY GLASSES WHEN REPAIRING OR HANDLING AN AIR BAG.

ALWAYS CARRY A LIVE AIR BAG MODULE WITH THE TRIM COVER POINTED AWAY FROM YOUR BODY.

ALWAYS PLACE A LIVE AIR BAG MODULE ON A BENCH OR OTHER SURFACE WITH THE TRIM COVER FACING UP.

NEVER PROBE THE CONNECTORS ON THE AIR BAG MODULE.

AIR BAG MODULES WITH DISCOLORED OR DAMAGED COVERS OR DEPLOYMENT DOORS MUST BE REPLACED, NOT REPAINTED.

Tools required:

T-20 and T-30 Torx Drivers	Socket Set
Safety Glasses	Torque Wrench
Flat Blade Screwdriver	

DISABLING AND REMOVAL OF THE AIRBAG MODULE

1. Position the steering wheel so that it is pointed straight ahead. Write down all of your radio presets as these may be lost when you disconnect the battery cable in step 2 below.
2. At the Smart Junction Box (SJB) located in the right hand lower kick panel, remove the cover and pull the Restraints Control Module (RCM); this should be fuse number 17 (10A). Turn the ignition to ON and monitor the airbag indicator light for at least 30 seconds, the light should remain lit continuously if the correct fuse has been removed. If it does not remain lit you have pulled the incorrect fuse and

must find the correct one before proceeding; refer to your vehicle manual for the correct fuse if it is not number 17. Once you have removed the correct fuse turn the ignition switch to OFF.

NOTICE - Disconnect the negative battery cable and wait at least **1 full minute** for the circuit to completely discharge before proceeding. (If your vehicle has any auxiliary batteries or power supplies disconnect these as well). **CAUTION:** Failure to fully deplete the backup power supply could result in an accidental deployment and possible injury.

3. Refer to Illustration 1 below and remove the plastic bolt caps (1) from the sides of the steering wheel by prying out with a small screw driver. Remove the airbag module bolts (2) found underneath these bolt caps with either an 8mm or 10mm socket.

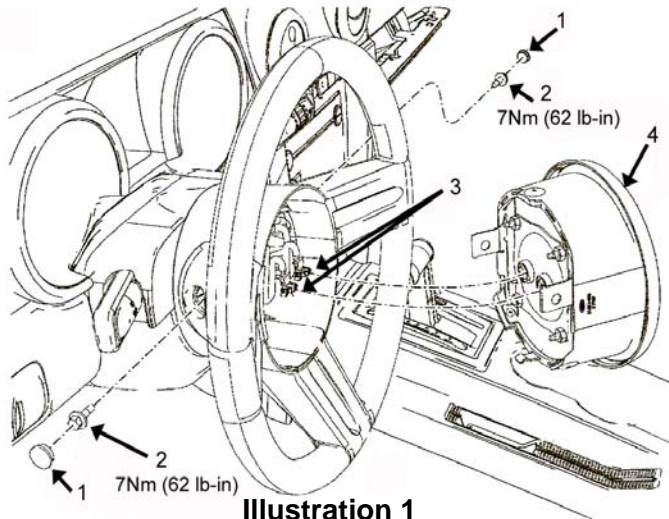

Illustration 1

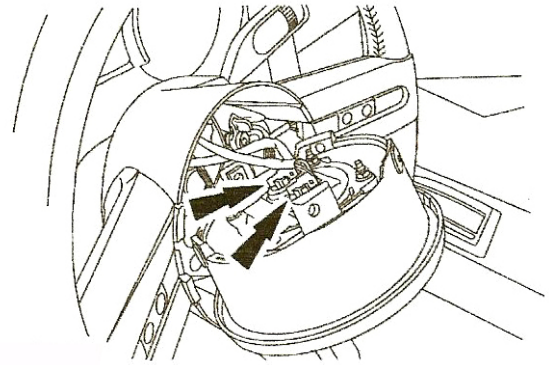

Illustration 2

4. Lift and partially remove the airbag module (4) from the steering wheel in order to expose the electrical connectors (3) on the back side. **Take care not to pull on any of the wiring.** The connectors are unique and cannot be reversed when connected so there is no need to mark them.
5. Disconnect the electrical connectors from the airbag module. (Illustration 2)
6. Remove the airbag module from the steering wheel and place the module face up on the floor, seat or work bench. If you carry the module make sure the trim cover is pointed AWAY from your body.

REMOVING THE STEERING WHEEL FROM THE VEHICLE

1. Remove the three (3) silver spoke trim finish panels by placing your finger tips under the trim at the outside end where it meets the grip of the wheel and gently pull upward. Once it starts to move it is easy to remove; just pull straight up.
2. Refer to **Illustration 3** and disconnect the horn lead by pulling off horn switch at the upper right tab. Disconnect the wheel switch wiring harness at the clockspring column connector. **Do not pull on the clockspring and do not turn the clockspring now or at any time during installation.**

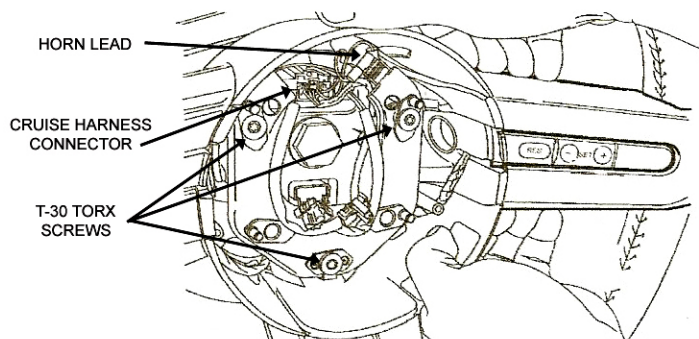

Illustration 3

3. Remove the horn switch by loosening the 3 T-30 Torx screws and remove the assembly from the wheel. After removing this assembly you will expose the cruise control switch wiring harness. This will also allow access to a T-20 Torx screw with a green ground wire which needs to be removed as well. (**Illustration 3**)
4. Loosen the steering wheel retainer bolt several turns, but do not remove completely from the shaft. Mark the shaft for alignment straight ahead. Pull up on the wheel while rocking back and forth until the wheel is loose on the shaft. Remove the retaining bolt and pull wheel from vehicle taking care to route all the wires through the opening in the wheel without pulling on them.
5. Pull the cruise control switches out of the wheel by inserting a finger under the inner part of the switch where the wiring harness connects. As you pull up you will feel one of the retaining tabs release; at this point you can grab the switch near the center and pull it straight up and out. Do not pull on the wiring harness. Repeat the procedure for the other switch.
6. Remove the switches and wiring harness as a unit from the original wheel by pushing the 2 plastic routing positioners out of the wheel from the backside with a small screwdriver. Pull the wiring out of the small molded in tracks and note how the wires route outside the 2 long projections that are part of the rear wheel shroud.
7. Remove the rear wheel shroud by removing the 4 T-20 Torx screws on the backside of wheel.

PREPARING NEW WHEEL FOR INSTALLATION

1. Reinstall the switches and wiring harness assembly from step 7 above in the same position as it came out. Pushing the plastic routing positioners back into the holes in the wheel and positioning the harness in the molded in tracks as before.
2. Reinstall the rear plastic shroud with the 4 screws previously removed in step 8 above and route wire harness around the tall projections as before. **NOTE:** Make sure the shroud fits into the narrow guide slots molded into the wheel.
4. Push the cruise switches into the new wheel by locating them above their alignment holes and pushing straight down to lock in both of the locator tabs. Reinstall the spoke trim finish panels removed earlier by positioning them above their alignment holes and pushing down into position. Do not force or you could break the trim, they should easily slide and lock into place.

INSTALLING NEW STEERING WHEEL

1. Position the new wheel onto the shaft orienting it to the mark made earlier. (Reference "Removing The Steering Wheel From Vehicle" step number 1 above). Route wires through opening as before.
2. Install the steering wheel retainer bolt and torque securely to 55N-m (41 lb ft).
3. Make sure the cruise wiring harness is positioned properly and reinstall the green ground lead using the screw previously removed and tighten securely.
4. Position the horn switch assembly and tighten the 3 T-30 Torx screws securely.
5. Reconnect the horn lead to the tab on the upper right of the switch.
6. Reconnect the cruise wiring harness to the clockspring mechanism coming from the column.
7. Position the airbag module near the wheel and re-connect the wire leads. As mentioned earlier each connector is unique and cannot be reversed. Match the connector key to the keyway in the airbag module and push securely into position. **Do not force the connectors or damage to the connector or module may occur.**

8. Position the airbag module into the wheel and reinstall the 2 airbag module retaining bolts removed earlier; tighten to 7 N-m (62 lb-in). Reinstall the plastic bolt plugs into the wheel.

REPOWERING AND CHECKING THE AIRBAG SYSTEM

Make sure no one is in the vehicle and there is nothing blocking or placed in front of the airbag module when the power is being reconnected. Failure to follow these instructions may result in serious personal injury in the event of an accidental deployment.

1. Turn the ignition switch from OFF to ON. Reinstall the restraint control module (RCM) fuse into the correct slot in the Smart Junction Box (SJB) and close the cover. Reconnect any auxiliary batteries or power supplies (if so equipped). Reconnect the negative battery cable.
2. Turn the ignition key from ON to OFF. Wait 10 seconds, then turn the key back to ON and visually monitor the airbag warning indicator. It may take approximately 30 seconds after the ignition switch has been turned from the OFF to the On position for the light to come on as this is the time required for the RCM to complete the testing of the circuit. The light should come on for 6 seconds then turn off. If a fault is present in the system the light will either fail to come on at all or remain lit continuously. If either of these occurs refer back to "Disabling and Removal Of The Airbag Module" to check your connections. If the light should flash and you hear an audible beep this means the RCM is not configured and you should take your vehicle to a Ford dealer immediately.
3. Remember to reset your radio station presets and clock and enjoy your new **GRANT REVOLUTION** steering wheel. When you first start the vehicle the engine may run less smoothly than before as the computer will have to reset itself due to the power loss but this will just take a moment or two.

If you need further assistance contact GRANT Technical Service Support at:

Phone (626) 305-0700

Fax (626) 305-0799

Email: customerservice@grantproducts.com

**Support Hours are 8:00AM to 5:00PM Pacific Time
Monday through Friday**



OUR LIMITED WARRANTY

We warrant this product for ninety (90) days from the date of original purchase to be free from defects in materials and workmanship. If, during this period, the product fails under normal usage because of a manufacturing defect, then we will replace or repair the item. To obtain repair or replacement under the terms of this warranty, notify us at 615 Elca Lane, Suite C, Brownsville, TX 75821. Proof of purchase and date of purchase are required to validate warranty.

All implied warranties, including warranty of merchantability, are limited to this same ninety-day period from date of original purchase. We are not liable for any direct or consequential loss of property damage arising from any use of this product. This warranty gives you specific legal rights, and you may also have other rights which vary from state to state. Offer good in U.S.A. and Canada only.

**GRANT PRODUCTS INTERNATIONAL, INC.
615 Elca Lane, Suite C
Brownsville, TX 75821**

On the Web: www.grantproducts.com

Rev. 5/10 by JF

Form 97581-00-01